

*Instruction Book For
Scenic Roller Projection
Screen*



The
POWER *In*
PRESENTATION PRODUCTS



DA-LITE SCREEN COMPANY, INC.

3100 North Detroit Street

Post Office Box 137

Warsaw, Indiana 46581-0137

Phone: 574/267-8101

800-622-3737

Fax: 574/267-7804

[http:// www.da-lite.com](http://www.da-lite.com)

e-mail: info@da-lite.com

PRE-INSTALLATION

1. Having decided on hooks, chains, cables or other mounting method, have mounting prepared before opening box. Do not mount screen against walls that might rub fabric.
2. Whatever mounting method is used, the center clamp should be mounted with a turnbuckle, so center hook, chain or cable is 4" shorter than the other two.

INSTALLATION

1. Remove lid from shipping container, being careful not to permit lid or any tools to fall on screen.
2. Remove screen from box by lifting roller at the ends. During installation handle unit only by ends of roller and top header. Do not grasp around fabric—do not rest unit on fabric.
3. Remove wrapping paper and unwind ropes.
4. With the screen lying on the floor, install the three clamps on the reinforcement tape on the header as shown in illustration A. Clamp assembly is shown in Illustration B. Drop the oblong ring in the slots of the two outside clamps before inserting bolts. Drop the closed loop of the turnbuckle in the slot of the center clamp before inserting bolt. Each clamp uses 3 bolts and nuts. Do not tighten nuts any more than finger tight. Make sure the ends of clamps do not push into the fabric. Pulleys at each end of header must be be in the vertical position, when hung for proper operation.
5. Adjust top header in fabric pocket to the 2-1/4" and 3-3/4" position shown on the drawing.
6. Hang the screen in place at 3 points only.

CAUTION! When this screen is shipped from the factory, there are 2-1/2 turns of rope around each end of the roller. Make certain that this is left unchanged to insure good operation.

CAUTION! Before Dropping fabric make certain ropes at end of bottom roller do not overlap. Overlapping of ropes will cause rope to work inward and thus damage the fabric.

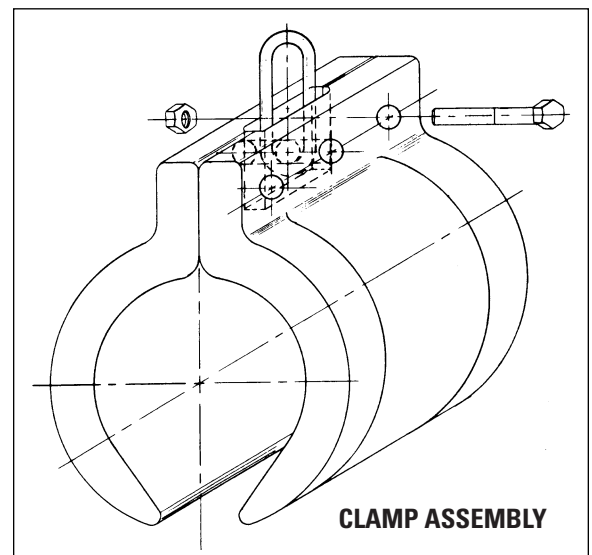

ILLUSTRATION B

SCREEN ADJUSTMENT

1. Lower screen slowly by gradually releasing ropes.
2. With screen in the "Down" position, turn the header in the fabric pocket carefully to adjust the pulleys to a vertical end position. Check the 2-1/4" and 3-3/4" end tube dimensions. Adjust the three clamps on the reinforcement tape. Clamps are not to push into fabric pocket. Tighten nuts on all bolts.
3. Total screen drop may be controlled by adjusting rope clamp. Do not adjust for more drop.
4. With unit in completely unrolled position, examine the screen carefully. If slight sag appears in center of fabric, adjust turnbuckle at center eye bolt until fabric hangs flat.
5. Screen may be raised by pulling on ropes. Tie off ropes to keep screen in raised position.
6. Protect your screen against damage and it will give many years of enjoyment.
 - a. When lowering screen, do so gently. Never allow it to drop uncontrolled.
 - b. Before raising screen, be sure both front and back sides are free from insects or any foreign matter.
 - c. Form the habit of looking in space between fabric and roller for foreign matter before raising screen.
 - d. Caution stage hands and others to avoid bumping screen with ladders, scenery, etc.

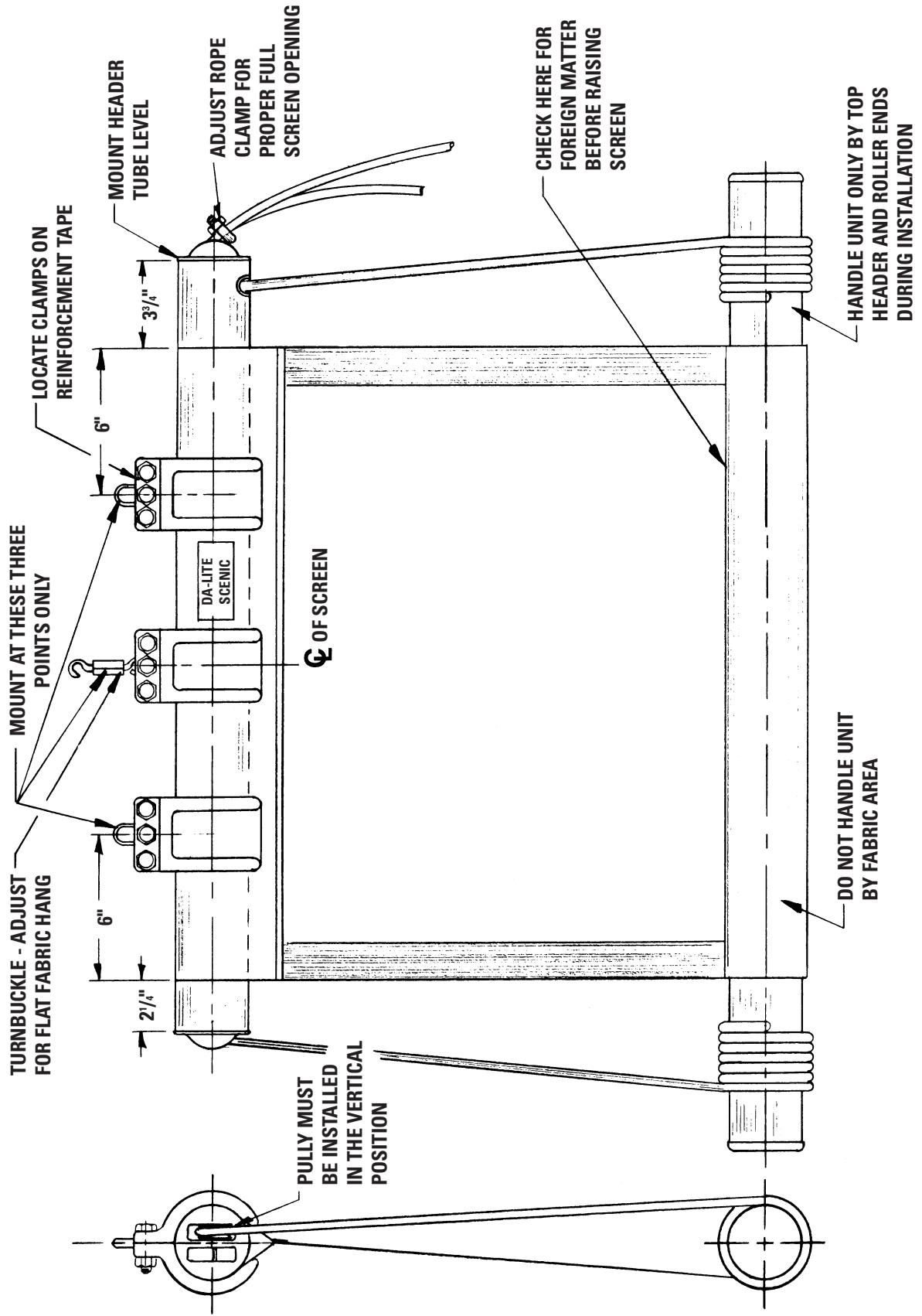

Illustration A

